



Full name: _____

Teacher: _____

Due date: _____

YEAR 8 MATHEMATICS

Assignment 1

2021

Outcomes Assessed

Working Mathematically: Students

- Communicates and connects mathematical ideas using appropriate terminology, diagrams and symbols **MA4-1WM**
- Applies appropriate mathematical techniques to solve problems **MA4-2WM**
- Applies Pythagoras' Theorem to calculate side lengths in right-angled triangles, and solves related problems **MA4-16MG**
- Calculates the perimeters of plane shapes **MA4-12MG**
- Uses formulas to calculate the areas of quadrilaterals and converts between units of area **MA4-13MG**
- Uses formulas to calculate the volumes of prisms and converts between units of volume **MA4-14MG**

Content Assessed

Refer to the attached assignment booklet and instructions. Each student is to complete tasks of their choosing.

Weighting

15%

Due:

This assignment is due to your classroom teacher 2 weeks from the date received (due in Week 7).

Penalties as per assessment booklet – Failure to submit the assignment within the negotiated time frame may result in N-award in Mathematics.

Gardner's Multiple Intelligences and Revised Blooms Taxonomy

This assignment has been designed to give all students an opportunity to best demonstrate their ability in Mathematics. Students can choose from tasks aligned to the different categories of Gardner's Multiple Intelligences. The tasks are also aligned to the Revised Bloom's Taxonomy - a multi-tiered model of classifying thinking according to six cognitive levels of complexity. Thus, students can choose tasks according to their preferred modes of learning, or try different styles of learning. Students are also able to revise and explore key concepts of this unit by completing lower-order tasks and then challenge themselves to develop their understanding and skills by completing higher-order tasks.

Instructions

You do not have to answer all the questions!

Each box in the Task Grid (on the next page) is a task.

1. **8MA1 and 8MA2** must include at least 2 tasks from the *creating* and at least 2 tasks from the *evaluating* column as part of their **30 marks**.
2. **8MA3, 8MA4, 8MA6, 8MA7 and 8MA8** must complete at least 1 task from the *creating* and at least 1 task from the *evaluating* column as part of their **25 marks**.
3. **8MA5** must complete a total of **20 marks**.
4. Most tasks will require you to write your answers on separate A4 paper that you will need to provide. Please clearly write your full name and the task number. Answer in sequential order. Use a separate sheet of A4 paper for each question.
5. Please highlight on the Task Grid which tasks you have completed.

Marking

Marks are awarded based on the difficulty and amount of work required to complete each task. Marking guidelines are provided under each task description.

Task Grid

Multiple Intelligences	Bloom's Taxonomy: Six Thinking Levels					
	Knowing	Understanding	Applying	Analysing	Creating	Evaluating
Verbal/Linguistic I enjoy reading, writing & speaking	1) Terminology 1 mark	2) Your words, not mine. 1 mark	3) Problems! Problems! 3 marks	4) Worldwide Measurement 2 marks	5) Pi Recital 2 marks	6) Repetitive Pythagoras 3 marks
Logical/Mathematical I enjoy working with numbers & science	7) Rounding Decimals 2 marks	8) Converting Units 3 marks	9) Distance Travelled? 2 marks	10) How long is a piece of string? 2 marks	11) Creating Triads 2 marks	12) How much is too much? 3 marks
Visual/Spatial I enjoy painting, drawing & visualising	13) Is it square? 1 mark	14) How many cubes? 2 marks	15) 3D Pythagoras 3 marks	16) Area Grid Puzzle 4 marks	17) Formulae Poster 4 marks	18) Optical Illusion 3 marks
Bodily/Kinaesthetic I enjoy doing hands-on activities, sports & dance	19) Counting Area 1 mark	20) Counting Area Again 2 marks	21) How much chalk? 2 marks	22) Picture Framing 2 marks	23) Make a rap/compose a song 3 marks	24) Work Samples 3 marks
Technology I enjoy using computers	25) The evolution of Theorems 2 marks	26) Online Game Khan Academy 2 marks	27) Perimeter vs Area (Party Planner) 3 marks	28) The maximum area problem 3 marks	29) Teach a lesson 3 marks	30) Evaluation Tool 3 marks

Task Details

Verbal/Linguistic

1) Terminology (1 mark)

Fill in the blanks. All terminology used below relates to the Measurement Unit.

- a) _y__t__u_e
- b) T___r_m
- c) _i_h_ A_g__
- d) P_t_a_o_e_n T_i_d
- e) C_n_i__t_e
- f) __r_m_t_r
- g) V__u_e
- h) H_c_a_e

Marking	
1 mark	All 8 terms have been correctly identified.
0.5 mark	Between 4 – 8 terms have been identified.

2) Your words, not mine. (1 mark)

In your own words, and using full sentences, describe the relationship between the sides in a right-angled triangle. That is, imagine you have to explain what Pythagoras' Theorem is to someone who has never seen it.

(Must be your own words, not the definition from somewhere!)

Marking	
1 mark	Adequately describes the theorem, explaining how the sides are related.
0.5 mark	Explanation is not entirely understandable. It contains some characteristics but not all.

3) Problems! Problems! (3 marks)

Circle the correct response in these three multiple choice questions:
Use the working space on the right side for your solutions.

a)

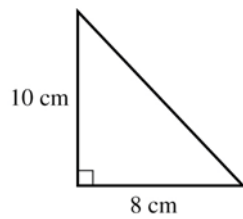

What is the length of the hypotenuse in the figure?

- A 6 cm
- B $\sqrt{74}$ cm
- C $\sqrt{108}$ cm
- D $\sqrt{164}$ cm

b)

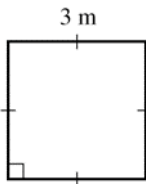

How long is the diagonal of the square?

- A 3.2 m
- B 4.2 m
- C 5.9 m
- D 6.1 m

c)

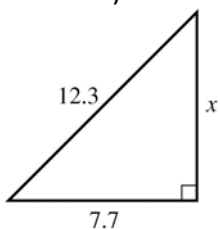

What is the value of the pronumeral correct to 2 decimal places?

- A 9.59
- B 10.32
- C 12.16
- D 13.73

Marking	
1 mark	Per correct answer with working out.

6) Repetitive Pythagoras (3 marks)

In the diagram pictured below, a side of square 1 is a diagonal of square 2. A side of square 2 is then a diagonal of square 3, and so on. If the side length of square 1 is 1 metre, what is the side length of square 5?

(Hint: You may assume the triangles are isoceles.)

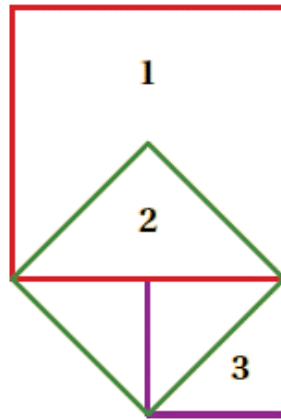

Marking	
1 mark	Can find the short side length of square number 2.
2 marks	Has found the side length of square number 2, and is working towards finding the side length of square 5
3 marks	Correctly finds the length of the side of square number 5, showing all working.

Logical/Mathematical

7) Rounding Decimals (2 marks)

Rounding numbers correctly is important! For example, in 1987 government in the UK underestimated inflation by 0.1%. This caused them to have to pay out an extra 100 million pounds (180.6 Australian Dollars) on things such as pensions.

Correctly round these numbers to the decimal places specified in the brackets.

- a) 6.4328 (1 decimal place)
- b) 34.35677 (2 decimal places)
- c) 0.0435 (3 decimal places)
- d) 159.9911 (1 decimal place)

Marking	
0.5 mark	Per correct solution.

8) Converting Units (3 marks)

Complete the questions below by converting:

- a) 15cm to mm
- d) 1550mm² to cm²

- b) 4.2km to m
- e) 93.3ha to m²

- c) 737 000cm to km
- f) 9500L to m³

Marking	
0.5 mark	For each correct calculation.

9) Distance Travelled? (2 marks)

An iron woman race involves 3 swim legs and a beach run, as shown in the figure below. What is the total distance covered in the race?

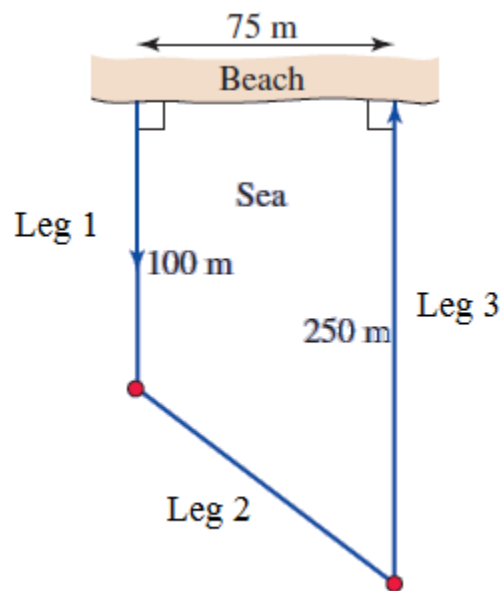

Marking	
2 marks	Correctly calculated the distance travelled and has shown adequate working out.
1 mark	Has calculated the wrong distance of leg 2 but has shown the correct process used to add the all distances together.

10) How long is a piece of string? (2 marks)

One quarter of a length of rope is cut off and used. Later on, two-thirds of the remainder is cut off and used. It is found that only 15 metres of rope remains. How long was the original rope?

Marking	
1 mark	Is working towards getting the correct answer but with mistakes.
2 marks	Correctly finds the length of the rope with adequate working.

11) Creating Triads (2 marks)

Pythagorean triads are 3 integers (whole numbers) that satisfy Pythagoras' Theorem. This means that the 3 numbers could be the sides of a right-angled triangle. Follow the steps below to successfully create your own Pythagorean Triad. You must show all steps to receive full marks.

Steps:

- 1) Start with any odd number, and make this the shortest length of the triangle (call it "a").
- 2) To find another short side (call it "b") use the formula $b = \frac{a^2-1}{2}$. Remember that "a" is your odd number from step 1.
- 3) You now have the two short sides of the triangle and can use $c^2 = a^2 + b^2$ to calculate the third side (hypotenuse, c).
- 4) List your Pythagorean Triad. E.g. {3, 4, 5}. Do not use this one.

Marking	
2 marks	Has followed the steps and shown all working to create their own Pythagorean Triad.
1 mark	Has listed a Pythagorean Triad but shown minimal working out.
1/2 mark	Has listed a Pythagorean Triad with no working.

12) How much is too much? (3 marks)

A fish tank is 0.6 m long, 0.3 m wide, 0.4 m high and contains 70 L of water. Rocks with a volume of 3000cm^3 are placed into the tank. Will the tank overflow, and if so, how by how much? Show all working.

Marking	
3 marks	Student has correct answer with all the correct calculations.
2 marks	Student has most of the following correct but has not arrived at the correct solution: - calculation of the volume of the fish tank - conversion of units of volume correct - conversion of units of volume to capacity
1 mark	Student is working towards the correct solution, or has the correct solution with no working.

Visual/Spatial

13) Is it square? (1 mark)

A builder is checking the timber support structures in part of a house. To ensure the structure is strong enough, it must contain a right angle. He believes that this triangle does not fit the brief. Prove that the triangle below does not contain a right angle.

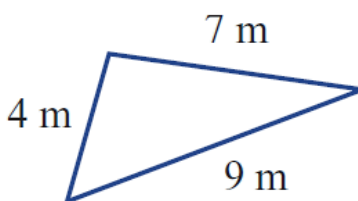

Marking	
1 mark	Has used Pythagoras' Theorem and shown all working to prove the triangle does not contain a right angle.

14) How many cubes? (2 marks)

Use the diagram below to help you answer the questions.

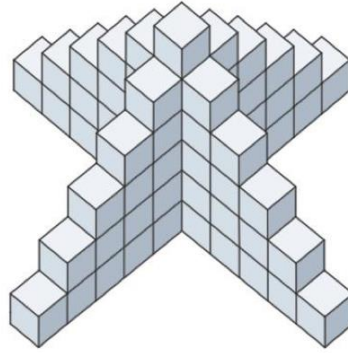

- a) How many cubes are needed to build this tower?
- b) How many cubes would be needed to build a tower like this, but 12 cubes high?
- c) In words or algebraically, explain/write a rule that would help you count the number of cubes for a tower like this that was 100 cubes high.

Marking	
0.5 mark	Part a) answered correctly.
0.5 mark	Part b) answered correctly.
1 mark	Explanation/rule is correct and well articulated. This could be used to find the height of a tower 100 cubes high and hence any similar tower.

15) 3D Pythagoras (3 marks)

Pictured to the right is the tub/tray from a ute. It is 1560mm long, 1520mm wide and 49cm high.

- a) Convert the 3 measurements to metres.
- b) Using Pythagoras' Theorem twice, determine the longest length any item can be such that it will fit in the tub/tray. Show all working and round your answer to 2 decimal places. (Hint: You will need to find the diagonal length of the bottom tub. Using this answer and the height, you can determine the 3D diagonal length).

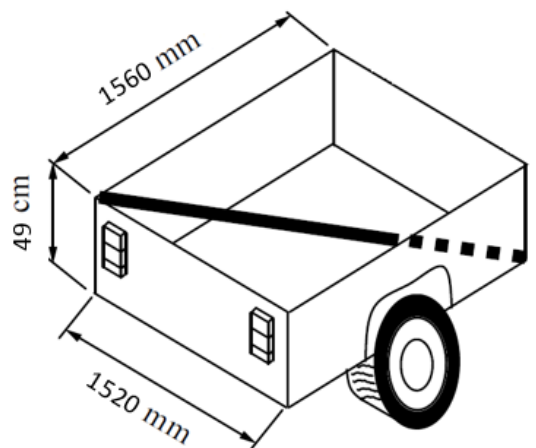

Marking	
1 mark	Part a) answered correctly.
2 marks	Part b) answered correctly with adequate calculations.

16) Area Grid Puzzle (4 marks)

Attached at the back of this booklet (APPENDIX A) is a series of shapes. You are to cut out each shape. Using all 12 pieces in any arrangement, fit these shapes in to the rectangles pictured below. Take a photo of each rectangle completed and attach it to the assignment.

Here is an example of a completed one (Do not use this solution as your own – there are many!)

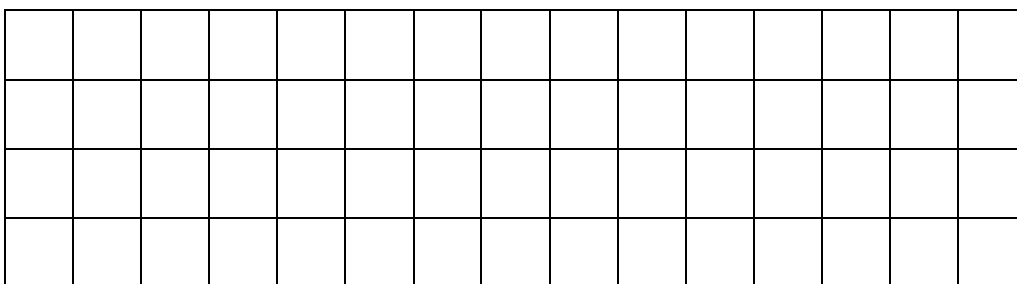
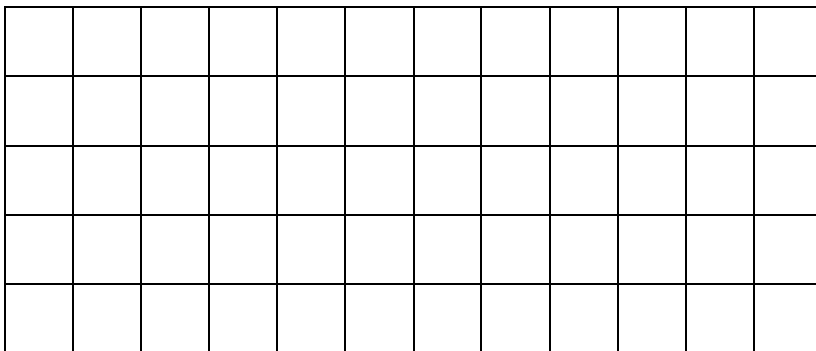
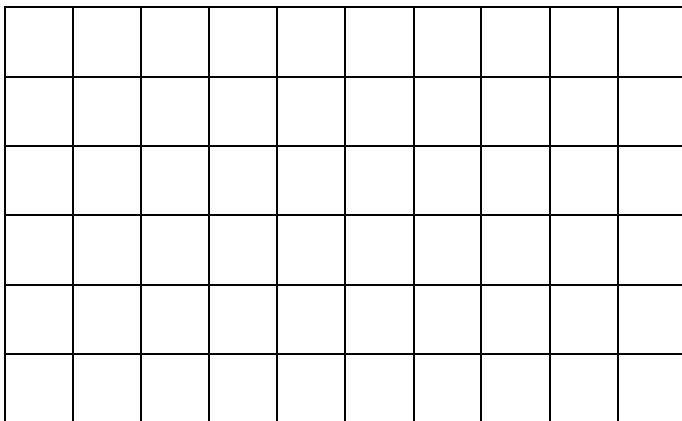
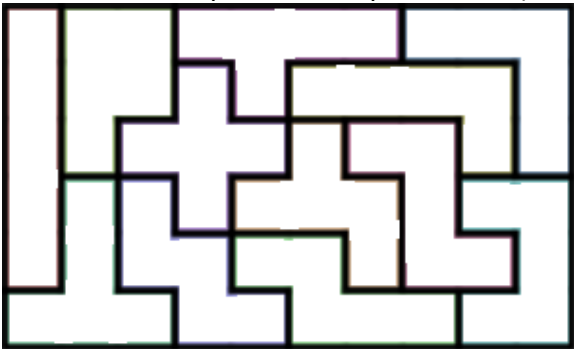

Marking	
1 mark for each rectangle	Photo correctly depicts the rectangle being successfully covered by the cut-out shapes.

17) Formulae Poster (4 marks)

Design an A4 summary sheet with useful measurement formulae to be displayed in class. Make sure to include the following:

- Pythagoras' Theorem (finding the hypotenuse)
- Pythagoras' Theorem (finding the short side)
- Area of Squares, Rectangles and Triangles
- Area of Special Quadrilaterals (Kite/Rhombus, Parallelogram, Trapezium)

Marking	
4	- Two Pythagorean formulas with an example of each - The area of 6 shapes with the appropriate formula and one solved example for each shape.
3	- Summary page has the 2 Pythagorean formulas but is missing a shape. - Shapes present have the appropriate formulae and examples.
2	- Summary page has all shapes and appropriate formulae but no examples.
1	- Summary page has formulas listed but no shapes or examples.

18) Optical Illusion (3 marks)

This task combines art, mathematics and design. Optical illusions are geometric shapes and patterns, often coloured in black or white. Looking at the three examples below:

- a) In a short paragraph, explain what patterns cause the optical illusion.
- b) Create your own optical illusion on the grid provided at the back of the assignment (APPENDIX B). Write clear instructions on how you created your optical illusion.

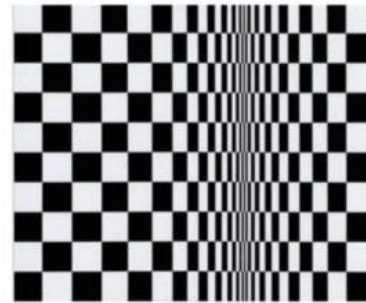
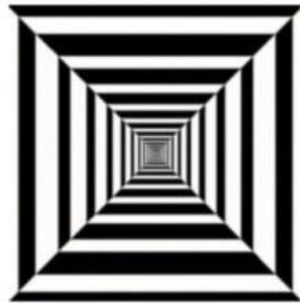
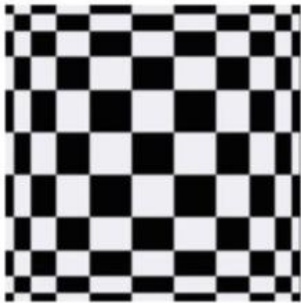

Marking	
3 marks	Student explains what is required to create an optical illusion. They have created their own and listed the steps.
2 marks	Student can explain the patterns required and has constructed an optical illusion, but with no steps listed.
1 mark	Optical illusion created.

Bodily/Kinaesthetic (Questions 19 to 24)

19) Counting Area? (1 mark)

To estimate the area by counting squares:

- count whole squares as 1 square unit
- count squares with more than half shaded as 1 square unit
- count squares with exactly half shaded as $\frac{1}{2}$ square unit
- do not count squares with less than half shaded.

There are 42 complete squares.	42	(✗)
There are 6 with more than half shaded.	+ 6	(✓)
There are 3 with exactly half shaded.	+ $1\frac{1}{2}$	(●)
	49 $\frac{1}{2}$	

$\therefore \text{Area} \approx 42 + 6 + 1\frac{1}{2} = 49\frac{1}{2}$ square units.

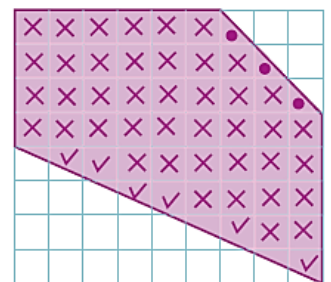

(QUESTION CONTINUES OVER THE PAGE)

Using the strategy outlined on the previous page, determine the area of the shapes outlined below.

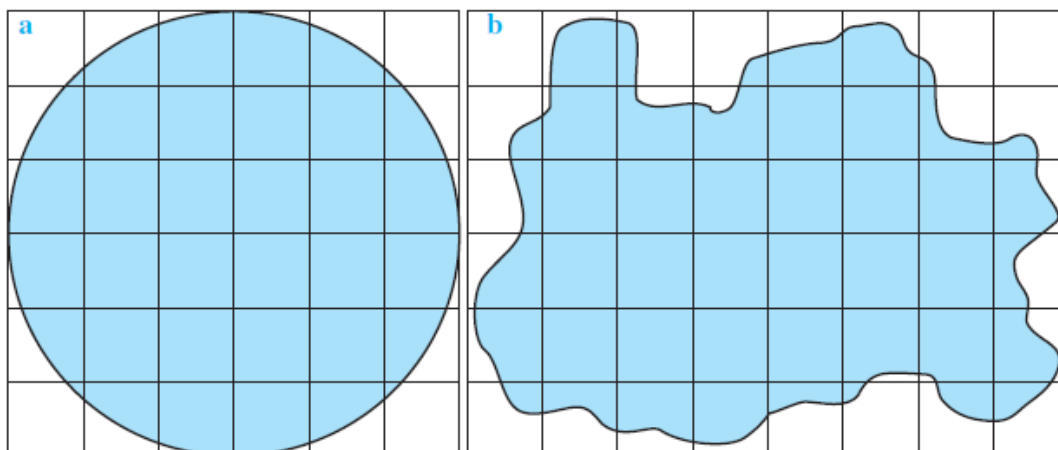

Marking	
1/2 mark	Correct answer and strategy applied for part a).
1/2 mark	Correct answer and strategy applied for part b).

20) Counting Area Again (2 marks)

You are going to use the strategy explained in question 19 (previous page) to estimate the area of the following two items:

- A phone/Ipod
- Your hand

On the grid paper located at the back of this assignment (APPENDIX C), trace your hand and your device onto the paper. Use the strategy from question 19 to then count the area of these items. Clearly mark the full squares, the half squares and the less than half squares on the sheet of paper.

NOTE: You may want to bring your fingers together and get someone else to trace around the outside of your whole hand.

Marking	
2 marks	Student has a neat outline of the items and has correctly estimated the answer of that shape.
1 mark	Area closely estimated but drawing is messy or incorrect counting process has been used.

21) How much chalk? (2 marks)

A grass tennis court has white chalk lines, of which are shown in feet. Find the total number of feet of chalk required to mark all the lines of the tennis court pictured below.

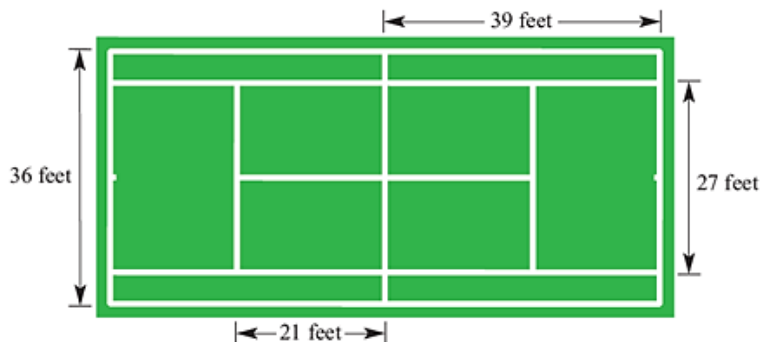

Marking	
2	Correct answer with all working clearly set out.
1	Correct answer with no working shown or some correct working shown.

22) Picture Framing (2 marks)

A photograph 60 cm in length and 40cm in breadth is to be framed with timber. When completed, there will be a 4cm border around the photograph.

- Draw a diagram to show the photograph, including the border. Label all dimensions.
- What length perimeter around the outside of the timber border?

Marking	
1 mark	Photograph and framing correctly drawn with correct dimensions.
1 mark	Perimeter around the framing correctly calculated.

23) Make a rap/ compose a song (3 marks)

Compose a rap or a song that includes everything “measurement.” You may wish to perform it and hand in the video or simply write it down and submit a written version

Marking	
3	Song/rap is of suitable length, flows, is creative and involves a variety of measurement concepts.
2	Song/rap length does not flow OR only a small amount of measurement terms are mentioned.
1	Song/rap has minimal relevance to measurement, does not flow and is an unsuitable length.

24) Work Samples (3 marks)

For the task below, the solutions have been completed by another student. However, some of the worked solutions are incorrect.

- a) Next to each question, identify if the problem has been completed correctly or incorrectly.
- b) If the question is wrong, circle the error and write what they did wrong

Find the value of the missing side in each figure, rounding your answer to two decimal places.

(a)

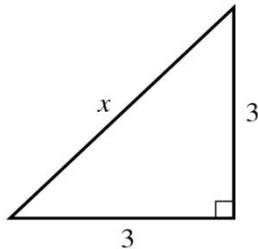

(b)

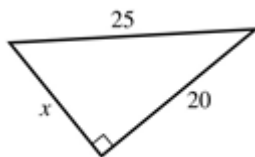

- (c) The span of a roof for a doll's house is 3.2 m and it rises to a height of 0.6 m in the centre. If the width of the timber is the same as the depth of the house, what length of timber is needed to create the sloping sides of the roof?

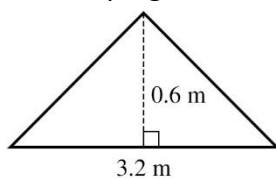

Marking	
1 marks per part	Correctly identifies the question as correct or incorrect, and circle and explains the error if present.

Technology

25) The evolution of theorems (2 marks)

Pythagoras is credited for “proving” the relationship between the three sides of a right-angled triangle. However, people had been using these properties well before Pythagoras. Your task is to research two other people/groups who used the theorem before Pythagoras. Present a short paragraph outlining who used it and where it was used.

Marking	
2 marks	Paragraph correctly outlines two people/groups who used it and what for.
1 mark	Paragraph outlines one person or doesn't list where it was used.

26) Online Game (2 marks)

The given link is an online set of questions on Pythagoras' Theorem. Click on the link below and complete the quiz.

Please attach screenshots of each one completed. If you get stuck you can access the videos on the taskbar on the left hand side.

<https://www.khanacademy.org/math/cc-eighth-grade-math/cc-8th-geometry/pythagorean-theorem-application/e/use-pythagorean-theorem-to-find-area>

Marking	
1 mark	Quiz is incomplete and/or incorrect answers.
2 marks	Quiz is complete and contains one error or less.

27) Perimeter vs. Area (Party Planner) (3 marks)

Visit the website <https://www.brainpop.com/games/areabuilder/> and complete the six level two questions (you must screenshot the outlay of the 6 completed answers, put them in a word document and attach it to your assignment). Screenshot must contain BUILD IT! and not SOLUTION! In the left hand corner because solution is a given response.

Marking	
3	All 6 solutions answered and have been successfully completed with the correct layout attached.
2	4 of the 6 solutions answered and have been completed with the correct layouts attached.
1	2 of the 6 solutions answered and have been completed with the correct layouts attached.

28) The maximum area problem (3 marks)

A farmer is using 20 metres of fencing to make a rectangular goat pen. He wants to know what length and width of the rectangle will give him the greatest paddock area? Set up the spreadsheet shown below and finish it to calculate the area of rectangles with a perimeter of 20. Copy the formula in each column down to row 11 and print your results.

	A	B	C	D
1				
2	Length	Width	Area	Perimeter
3	1	9	=A3*B3	=2(A3+B3)
4	2	8	=A4*B4	=2(A4+B4)
:	:	:	:	:
11	9	1	=A11*B11	=2(A11+B11)

- a) What length and width gives the largest area?
- b) What length and width would give the greatest area using 36 metres of fencing?

Marking	
3	Spreadsheet results are correct and the student has identified the length and width that gives the largest area. Prediction for length and width for question b) is correct.
2	Most of spreadsheet is correct and answer a) and b) is correct OR spreadsheet is correct with one answer being correct.
1	Part of spreadsheet is correct OR answer a) or answer b) is correct.

29) Teach a lesson (3 marks)

Create a short lesson teaching a measurement concept using a piece of technology (you may want to use programs such as PowerPoint or Prezi etc.) Film yourself delivering the lesson. The lesson must go for approximately 3 – 5 minutes.

Marking	
3	Lesson contains an introduction, body and conclusion. The concept has suitable definitions, formulae and examples. The lesson is easy to follow and adequately explains a measurement concept.
2	Lesson has definitions, formulae and examples but the explanation of the concept is basic and lacks sufficient demonstrations.
1	Lesson has minimal information and a basic explanation of a concept.

30) Evaluation Tools (3 marks)

Create a quiz using technology (e.g. Quizlet, Kahoot!, Jeopardy, Quizizz). The quiz must be your own and have a minimum 10 questions. It should ask questions regarding measurement, be challenging and have the correct solutions present.

Screenshots are to be attached to the assignment.

Marking	
3	The quiz tests concepts currently studied in measurement. It has a minimum of 10 questions with the correct answers present.
2	Some questions not currently studied in the measurement unit OR some of the answers are incorrect.
1	Quiz has less than 10 questions.

BLANK PAGE

APPENDIX A (Task 16)

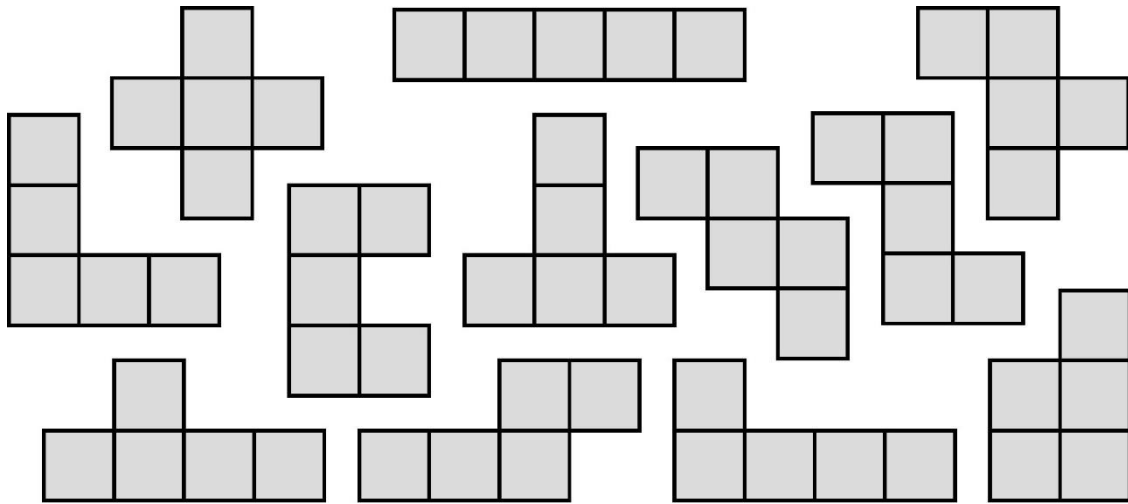

APPENDIX B (Task 18)

